

()
INTERSTATE COUNCIL FOR STANDARDIZATION, METROLOGY AND CERTIFICATION
(ISC)

IEC 62841-2-4-
2015

,

-

2 - 4

-

**(IEC 62841-2-4:2014,
Electric motor-operated hand-held tools, transportable tools and lawn and garden
machinery — Safety — Part 2-4: Particular requirements for hand-held sanders
and polishers other than disc type, IDT)**



2016

IEC 62841*2-4—2015

1.2—2009 « 1.0—92 « »

1 « » (« »)

5

2 8 262 « -

3 10 2015 . 48) (-

(1) 004-97	(3100) 004- 97	
	AM KG RU TJ	

4 18
2016 . N9 340- IEC 62841 -2-4—2015
1 2017 .

5 IEC 62841-2-4:2014 « -
2-4. » («Electric motor-operated hand-held tools, transportable tools and lawn and garden machinery — Safety — Part 2-4: Particular requirements for hand-held sanders and polishers other than disc type», IDT).

1.5—2001 (3.6).
IEC/TC116 Safetyof motor-operated electric tools ().

6 010/2011 « », 004/2011 « -
»

7

IEC 62841-2-4—2015

«(« », — () —
« ».
».

(www.gost.ru)

© . 2016

IEC 62841-24—2015

1	1
2	1
3	1
4	2
5	2
6	,	2
7	2
8	2
9	2
10	2
11	2
12	2
13	3
14	3
15	3
16	3
17	3
18	3
19	4
20	5
21	5
22	5
23	5
24	5
25	5
26	5
27	5
28	,	5
	1 ()	7
	()	9
	()	10
	10

		IEC62841 -1 —2014 «		-
			1.	-
		IEC 62841-1:2014 «		-
1.	».			-
				-
		IEC 62841-1:2014.		-
			IEC 62841-2-4:2014.	-
		IEC 62841-1:2014.	101.	-
				-
		3		-
		1.5—2001.		-

IEC 62841-2-4—2015

2-4

Electric hand-held tools, transportable tools and lawn and garden machinery. Safety and test methods. Part 2-4.
Particular requirements for orbital sanders and belt sanders

— 2017—01—01

1

IEC 62841-1

IEC 62841-2-3.

2

IEC 62841-1.

3

IEC 62841-1

- 3.101 (sander);
- 3.102 (polisher);
- 3.103 (belt sander);
- 3.104 (drum sander or polisher);
- 3.105 (orbital sander or polisher/oscillating sander or polisher);
- 3.106 (random orbit sander or polisher);

IEC 62841*2-4—2015

3.107 (reciprocating sender or polisher):

4

IEC 62841-1.

5

IEC 62841 >1

5.17

6

IEC 62841-1.

7

IEC 62841-1.

8

IEC 62841 -1

8.3

8.14.1

8.14.1.101

8.14.1.101

9

IEC 62841-1.

10

IEC 62841-1.

11

IEC 62841-1.

12

IEC 62841-1.

13

IEC 62841-1.

14

IEC 62841-1.

15

IEC 62841-1.

16

IEC 62841-1.

17

IEC 62841-1

17.2

0.9 24 1.1 24 0.9 24- 1,1 ()

18

IEC 62841-1

18.8

4.

4—

- , -	
	-
,	
,	-
- , -	b

IEC 62841*2-4—2015

4

	-
	-
	-
18	
23.3	

19

19.1 (62841 *1 :

19.1.101 19.1.101—19.1.103.

1) 8 1 2

2) (101). 7 (102).

19.1.102 102. (). 19.1.101.

a)),). :

8.14.2) 6) 100 .

b) 12

19.1.103

19.6

20

20.5 IEC 62841-1 : ,

21

21.18.1 IEC62841-1 :

21.35 : -

• 100 ?; -

• ; -

• 200 ²,
4)) 8.14.2. -

21.30

22

IEC 62841-1.

23

IEC 62841 -1.

24

IEC 62841-1.

25

IEC 62841-1.

26

IEC 62841-1.

27

IEC 62841-1.

28

IEC 62841-1.

IEC 62841*2-4—2015

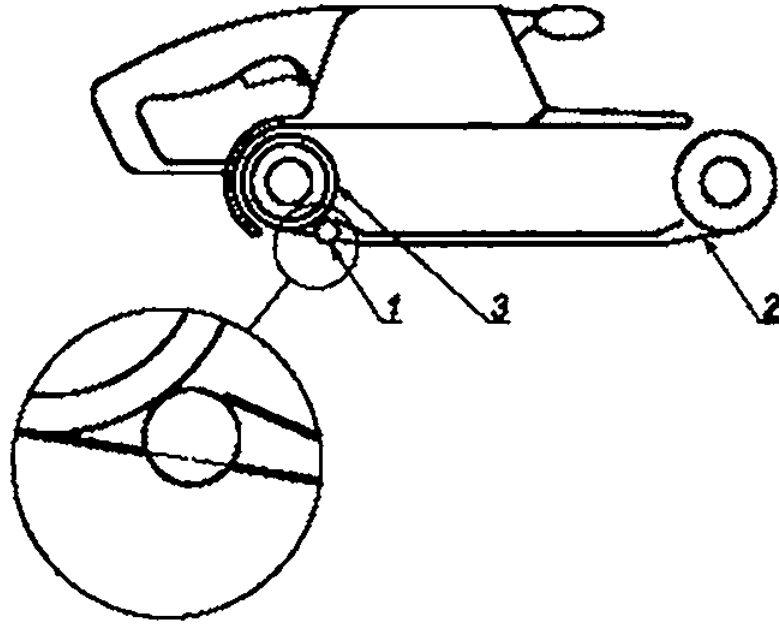

1 — щуп диаметром 8 мм, 2 — абразивная лента; 3 — ближайший к оператору барабан

101 —

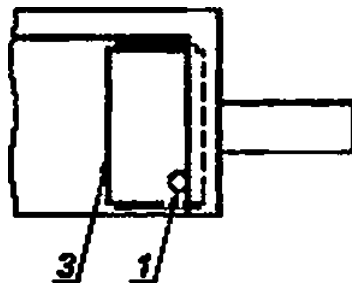
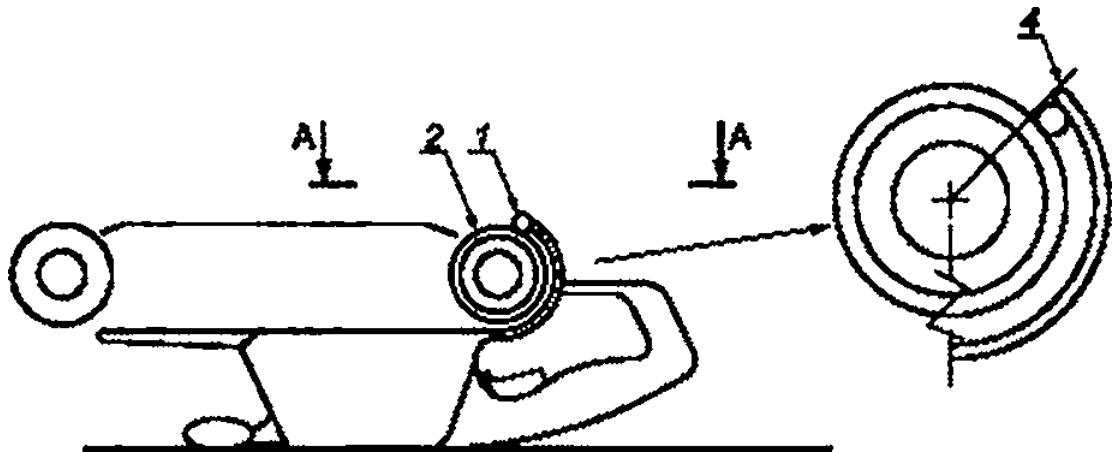

1 —

7 .2—6
:4—

6 :3—

102 —

IEC 62841-1

:

()

1.2 (- . 2)

1 62841-1

:

1.2.4

:

1.2.4

1.3

IEC 62841-1

:

1.3.3.2

:

1.101

1.3.5.3

1.101 1.102.

1.101 —

	400 400 20 .
	160
	- 30 1 S . , 1.S 0: . - SO 5 . 1.5 : - , ,
	1 . , -

1.102 —

	400 400 20 .
	• 30 1.5 . , 1.5 . 1.5 ; • 50 5 . - , ,

IEC 62841-24—2015

I.3.6.2

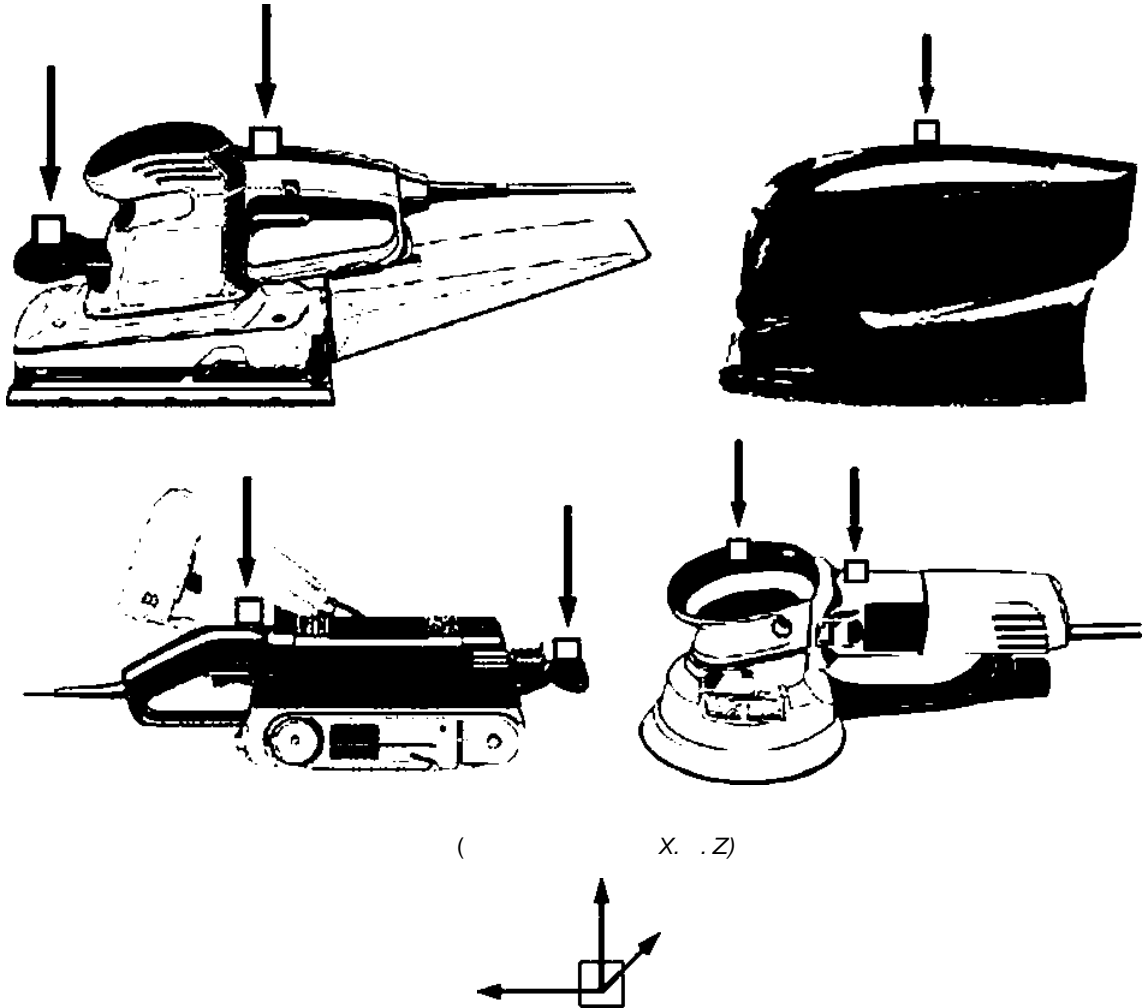

1.101 —

()

.1

.8.14.1.101

.17.2

.20.5

.21.30

IEC 62841*2-4—2015

()

.1

IEC 62641-1:2014		IEC 62641-1—2014 « , - - 1. »
— 8		

IEC 62841-1

IEC 62641-2-3 Electric motor-operated hand-field tools, transportable tools and lawn and garden machinery — Safety — Part 2-3: Particular requirements for hand-held grinders, polishers and disc-type senders (2-3.)

621.869:669.01:006.354

25.140.20
25.140.30
25.080.50

: , - , ,

A.W.

20.05.2016. 01.06.2016. 60>84^ . . . 1.66.

. . . 1.40. 30 . . 1376.

». 123665 . , 4.

www.gostinfo.ru mro@gostinfo.iu