



**7640-76**

**7640-76**

**Cylindrical gear grinders with cone grinding wheel.  
Standards of accuracy**

38 1562

01.01.78

. 1 — 18.

( , . 2).

1.

1.1.

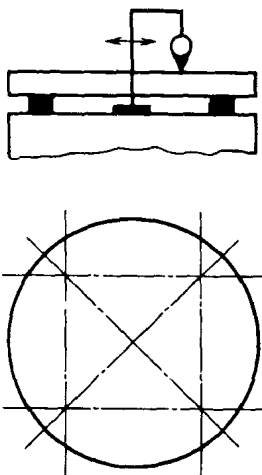

Черт. 1

320	6	4
320 500	8	5
	10	6
» 800 » 1250	12	8

— 22267, . 4, 3 ( . 1) ,

( , . 1, 2).

© © , 1976  
© , 1998

1.2.

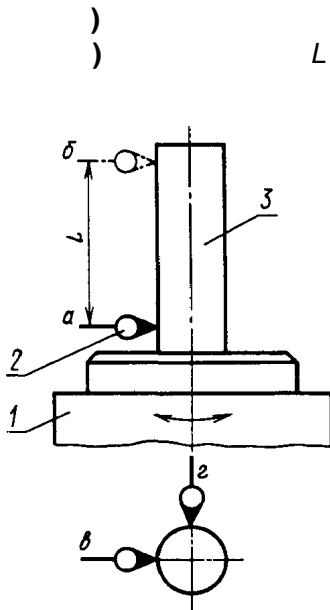

Черт. 2

);

320	1.2	—	2,5	i,6
	1.26	150	4	2,5
. 320 500	1.2	—*	3	2
	1.26	200	5	3
. 500 800	1.2	—	4	2,5
	1.26	300	6	4
. 800 1250	1.2	—	5	3
	1.26	300	8	5

2

1

3

2

90°

( , . 1,2).

1.3.

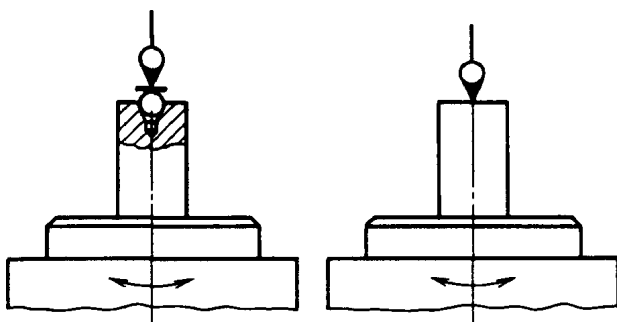

Черт. 3

320	3	2
. 320 500	4	2,5
» 500 » 800	5	3
» 800 » 1250	6	4

3

— 22267, .17, 1 ( .3).

( , . 1,2).

1.4.

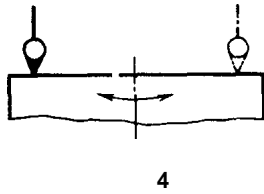

			4
320	8	5	
. 320 500	10	6	
» 500 » 800	12	8	
» 800 * 1250	16	10	

— 22267, . 18,

1 ( . 4).

0,4

( , . 1,2).

1.5.

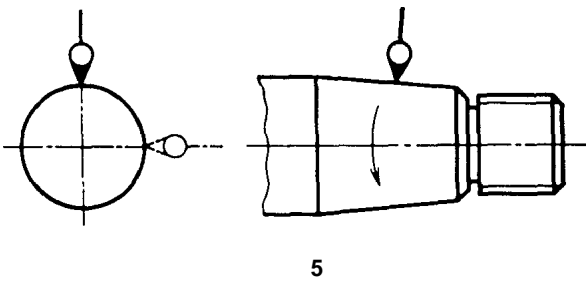

			5
500	3	2	
. 500 1250	4	2,5	

— 22267, . 15,  
( , . 1,2).

1 ( . 5).

1.6.

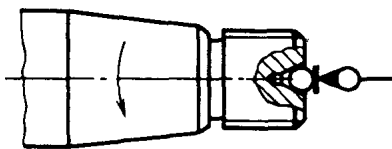

Черт. 6

			6
500	2	1,2	
. 500 1250	3	2	

— 22267, . 17,  
( , . 1,2).

1 ( . 6).

1.7.

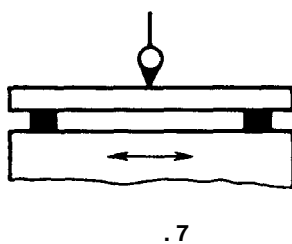

			7
160	8	5	
. 160 250	10	6	
» 250 » 400	12	8	
» 400 » 630	16	10	

— 22267, .6, 1 ( .7).

( 1.8, . 1,2).

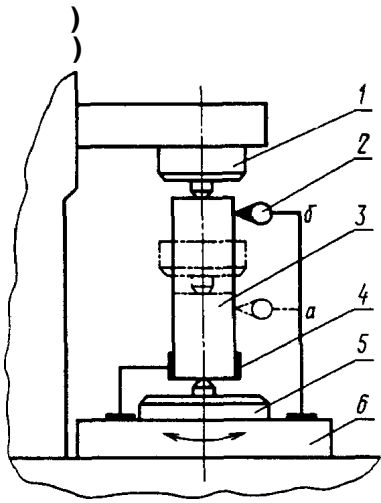

.8  
6

3  
2

6 360

( 1.9, . 2).

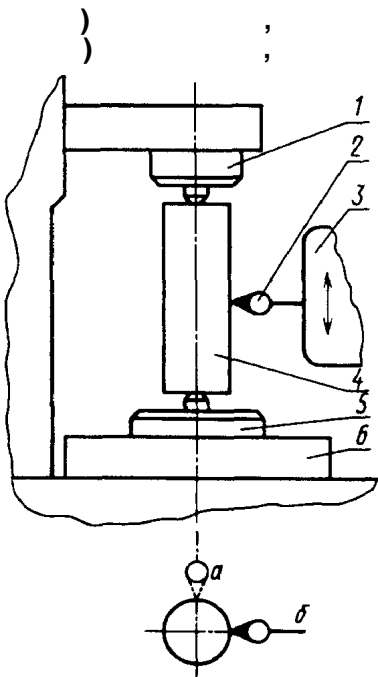

Черт. 9

):

			8
320	1.8	6	4
	1.86	10	6
. 320 630	1.8	8	5
	1.86	12	8
. 630 1000	1.8	10	6
	1.86	16	10

5

4.

6

9

160	1.9	5	3
	1.96	6	4
. 160 250	1.9	6	4
	1.96	8	5
250 400	1.9	8	5
	1.96	10	6
400 630	1.9	10	6
	1.96	12	8

6

5

1

4

3

2

( 180°).

1.2.

( 2).

1.10.

( -

)

10

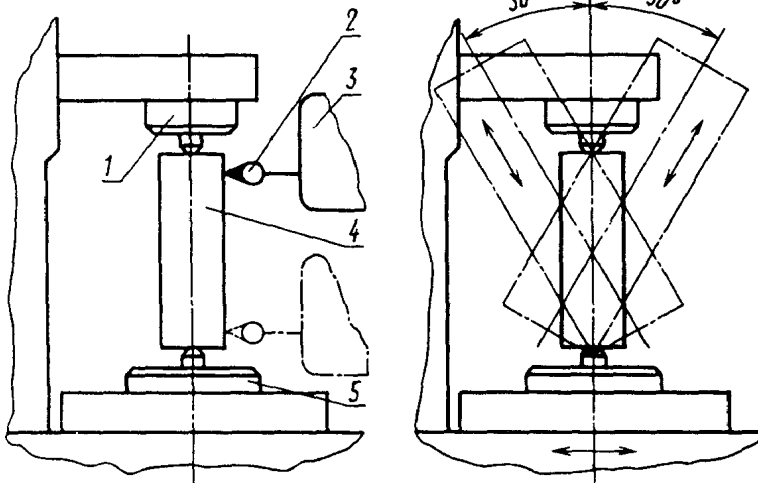

160	8	5
160 250	10	6
» 250 » 400	12	8
400 * 630	16	10

Черт. 10

1.9.

5

1

4

2

3

30 °

( )

)

( 180 )

1.2.

( 2).

1.11.

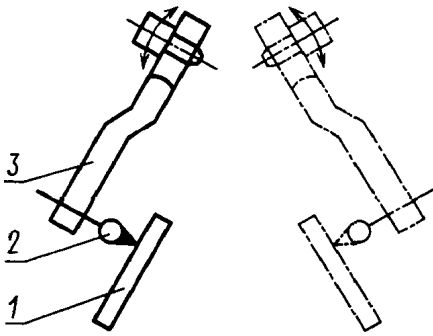

Черт. 11

1250	1	1

11

1.12.

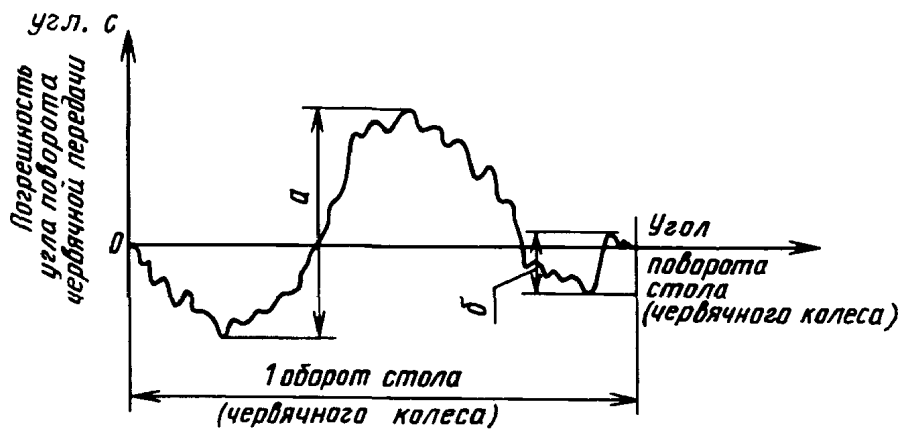

Черт. 12

320	1.12	20	12
	1.126	8	5
320 500	1.12	16	10
	1.126	6	4
500 800	1.12	12	8
	1.126	5	3
800 1250	1.12	10	6
	1.126	4	2,5

( . 2).

— ;  
— ;  
( . 2.1 2.2).  
( . 1,2).  
1.13.  
30°

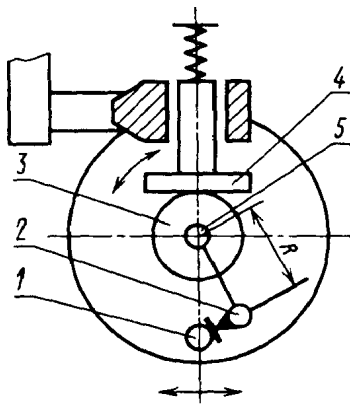

Черт. 13

320	6	4
. 320 500	8	5
» 500 » 800	10	6
» 800 » 1250	12	8

13

5, 1.9 1.2, 3  
4  
2  
1

$$\frac{R_{max}}{R} — ;$$

( . 2.1 2.2).  
( . 2).  
2.  
( :  $D = (0,5-1) / >$  , \* 0,75 /  $> 0,1 1>$  , />  
D, —



Z - , ,

d— ;  
 — ;  
 '— ;  
 ( , . 1,2).

2.1.

14

320	10	6
. 320 500	8	5
» 500 » 800	6	4
» 800 » 1250	5	3

( , . 1,2).

marapt

1643

$$I = M_{r_{pt}} |>$$

2.2.

15

320	32	20
. 320 500	25	16
» 500 » 800	20	12
» 800 » 1250	16	10

( , . 2).

2.3.

16

320	6	4
. 320 500	8	5
» 500 » 800	10	6
» 800 » 1250	12	8

90

( , . 1,2).

2.4.

17

40	6	4
. 40 60	8	5
» 60 » 100	10	6
» 100 » 160	12	8
» 160 » 250	16	10

90 °

( , . 2).

2.5.

18

	<i>Ra</i>	
	2789, ,	
		» vrnniu QO <sup>0</sup> \ * ' ' - *»-
1250	0,8	0,63 - ( , . 1, 2).

1. -

... ; - ; ... ; ... ; ... ; ... ; ... -  
; ... ; ...

2. 28.09.76 2221

3. 7640-67

4. -

--	--

8-82  
1643-81  
2789-73  
22267-76

2.1  
2.5  
1.1, 1.3—1.7

5. 22.06.88 2056

6. 1988 . ( 1-84, 10-88) ( 1998 .) 1, 2, 1983 .,

..  
..  
..

021007 10.08.95. 02.10.98. 138 . 1393. . 756. 05.11.98. . . . 1,40. - . . 1,00.  
 , 107076, , ., 14.  
 — .“ 080102 ”, , ., 6.